

OVER-THE-SIDE HEATERS immersion heaters

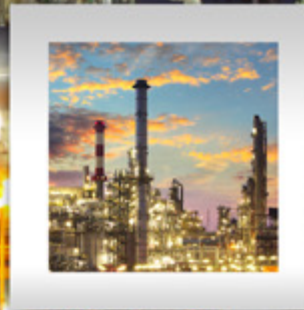
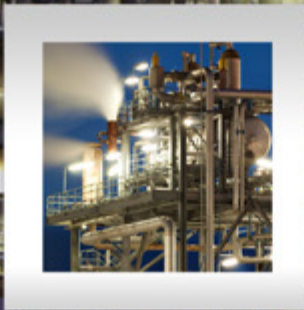

OVER-THE-SIDE IMMERSION HEATERS

immersion heaters

OVERVIEW

WATTCO™ over-the-side immersion heaters are made of sidemounted tubular elements. Perfectly designed for freeze protection, for heating viscous solutions, water, oils, solvents, salts, and acids. These heaters are mainly used in solutions requiring easy removal of heaters for cleaning or inspection purposes.

KEY FEATURES

- » Standard size: 1-inch conduit openings
- » 0.315", 0.375", 0.430", 0.475" diameter element
- » Sheath materials:
 - Stainless steel for stainless steel riser
 - Incoloy® for stainless steel riser
 - Steel for steel riser
- » Special sizes, wattages are available upon request
- » Custom-designed to meet your specifications

BENEFITS

- » Lightweight
- » Portable
- » Easy to install and to remove
- » Easy to maintain
- » Allow for 1 or 3 - phase operation
- » Maximize heat transfer
- » Provide uniform temperature
- » Moisture resistant
- » Oxidation and corrosion resistant
- » Built solidly
- » Designed for safety
- » Durable

APPLICATIONS

- » Water heating
- » Freeze protection
- » Viscous oils
- » Storage tanks
- » Degreasing tanks
- » Solvents
- » Salts
- » Paraffin
- » Caustic solutions



HOW TO INSTALL

Please follow these installation steps below (see Figures 1 and 2 on **page 3**) for the heated section of the heater:

Notes:

- » Heating element must always be fully immersed to prevent heater failure.
- » In determining the minimum liquid level required for proper use of heater, take into account the projected reduction of solution volume due to evaporation or removal of solution while heater is in use.

SELECTING

WATTCO™ OVER-THE-SIDE HEATER

The following sections will help you select the WATTCO™ over-the-side immersion heater that will meet the requirements of your application. Please call us at **1-800-4WATTCO (1-800-492-8826)** for further information or assistance.

APPLICATIONS	SHEATH MATERIAL	FLANGE MATERIAL
Water Non-corrosive solutions to copper	Copper	OTSC
Water rinse tanks Contaminants corrosive to copper Food solutions	Incoloy® / Stainless	OTSI
Oil-based solutions Chemical solutions not corrosive to steel	Steel / Stainless	OTSO
Corrosive contaminants where steel, stainless and copper are unusable	Inconel or Titanium	OTST

- Notes:**
- OTST titanium-sheathed heater comes with no stand-off brackets
 - Single phase or three-phase heaters are available

NEED ASSISTANCE?

Please call us at **1-800-4WATTCO (1-800-492-8826)** for further information.

Note: Lower watt densities usually offer longer service life.



OVER-THE-SIDE IMMERSION HEATERS

immersion heaters

TABLE 1
Single Element Type Over-The-Side Immersion (Figure 1)

KW	SHEATH	WATTS PER		CAT. NO.	NET WT LBS (KG)
		(in. ²)	(cm ²)		
STANDARD VOLTS: 208, 240, 480, 600 (1 PHASE)					
3	Copper	19	2.9	OTSC2530	8.8 (4)
5	Copper	32	5.0	OTSC2550	8.8 (4)
7.5	Copper	48	7.4	OTSC2575	8.8 (4)
3	304 S.S.	19	2.9	OTSS2530	8.8 (4)
5	304 S.S.	32	5.0	OTSS2550	8.8 (4)
7.5	304 S.S.	48	7.4	OTSS2575	8.8 (4)
3	Incoloy	19	2.9	OTSI2530	8.8 (4)
5	Incoloy	32	5.0	OTSI2550	8.8 (4)
7.5	Incoloy	48	7.4	OTSI2575	8.8 (4)
3	Inconel	19	2.9	OTST2530	8.8 (4)
5	Inconel	32	5.0	OTST2550	8.8 (4)
7.5	Inconel	48	7.4	OTST2575	8.8 (4)
3	Titanium	19	2.9	OTSZ2530	8.8 (4)
5	Titanium	32	5.0	OTSZ2550	8.8 (4)
7.5	Titanium	48	7.4	OTSZ2575	8.8 (4)

STAND-OFFS NOT PROVIDED
ON TITANIUM HEATER

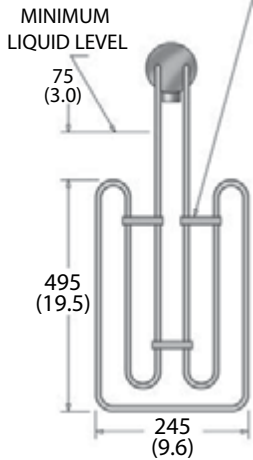
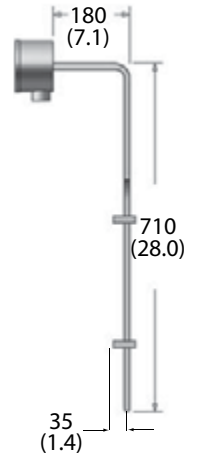

FIG. 1



Note: Special dimensions are available upon request.

WHEN ORDERING, PLEASE SPECIFY: Quantity, catalogue number, voltage, phase, and wattage.

TABLE 2
Three Element Type Over-The-Side Immersion (Figure 2)

KW	SHEATH	WATTS PER		CAT. NO.	NET WT LBS (KG)
		(in. ²)	(cm ²)		
STANDARD VOLTS: 208, 240, 480, 600 (1 OR 3 PHASE)					
9	Copper	19	2.9	OTSC3090	22.0 (10)
15	Copper	32	5.0	OTSC3150	22.0 (10)
22.5	Copper	48	7.4	OTSC3225	22.0 (10)
9	304 S.S.	19	2.9	OTSS3090	22.0 (10)
15	304 S.S.	32	5.0	OTSS3150	22.0 (10)
22.5	304 S.S.	48	7.4	OTSS3225	22.0 (10)
9	Incoloy	19	2.9	OTSI3090	22.0 (10)
15	Incoloy	32	5.0	OTSI3150	22.0 (10)
22.5	Incoloy	48	7.4	OTSI3225	22.0 (10)
9	Inconel	19	2.9	OTST3090	22.0 (10)
15	Inconel	32	5.0	OTST3150	22.0 (10)
22.5	Inconel	48	7.4	OTST3225	22.0 (10)

STAND-OFFS NOT PROVIDED
ON TITANIUM HEATER

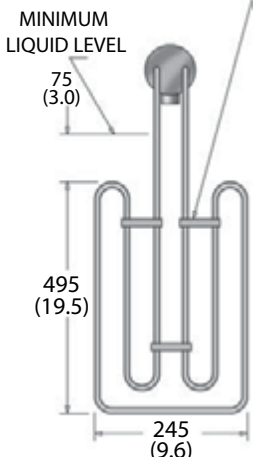
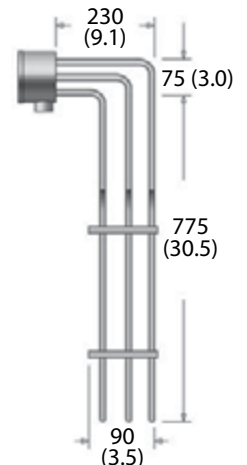

FIG. 2



Note: Special dimensions are available upon request.

WHEN ORDERING, PLEASE SPECIFY: Quantity, catalogue number, voltage, phase, and wattage.

OVER-THE-SIDE IMMERSION HEATERS

immersion heaters

APPLICATIONS

WATTCO™ bottom mounted heaters come with copper or Incoloy® sheaths for use in most liquid heating applications.

Refer to the construction chart below or call us at 1-800-492-8826 for further assistance in watt density and sheath selection.

CONSTRUCTION

SHEATH MATERIAL	HEATER TYPE
Copper	TLCLC
High density Incoloy®	TLCLI
Low density Incoloy®	TLCLI

EXTRA FEATURES

- » Specially configured wattage or voltage
- » Customized riser height
- » Other sheath materials than those listed are available
- » Built-in thermostat or high limit controls are available
- » 4" sludge legs
- » Passivation for Incoloy® and stainless steel sheaths
- » Explosion-proof terminal boxes are available

BOX TYPE	NO THERMOSTAT		WITH THERMOSTAT	
	K	L	K	L
MOISTURE RESISTANT (STANDARD)	3 1/2"	4 1/4"	6 1/4"	6"
EXPLOSIONPROOF	4 3/4"	4"	7"	5 5/8"

TABLE 3

Over-The-Side Heaters - Figures 3 & 4

KW	DIMENSIONS				SHEATH MATERIAL	WATTS PER		FIGURE 3 - TLCLC CAT. NO.	FIGURE 4 - TLCP CAT. NO.	NET WT. LBS (KG)
	B (FIG. 3) (mm)	B (FIG. 4) (in.)	B (FIG. 3) (mm)	B (FIG. 4) (in.)		(W/cm ²)	(W/in. ²)			
STANDARD VOLTS: 208, 240, 480, 600 (1 OR 3 PHASE)										
3	315	12.4	—	—	Copper	8.1	53	TLCLC303053	TLCP303053	11.0 (5)
6	565	22.2	400	15.7	Copper	9.3	60	TLCLC306060	TLCP306060	11.0 (5)
9	765	30.1	440	17.3	Copper	8.5	55	TLCLC309055	TLCP309055	13.2 (6)
12	940	37.0	480	18.9	Copper	8.4	54	TLCLC312054	TLCP312054	13.2 (6)
15	1115	43.9	520	20.5	Copper	8.4	54	TLCLC315054	TLCP315054	15.4 (7)
18	1315	51.8	560	22.0	Copper	8.2	53	TLCLC318053	TLCP318053	15.4 (7)
3	315	12.4	—	—	Incoloy	8.1	53	TLCLI303053	TLCP303053	11.0 (5)
6	565	22.2	400	15.7	Incoloy	9.3	60	TLCLI306060	TLCP306060	11.0 (5)
9	765	30.1	440	17.3	Incoloy	8.5	55	TLCLI309055	TLCP309055	13.2 (6)
12	940	37.0	480	18.9	Incoloy	8.4	54	TLCLI312054	TLCP312054	13.2 (6)
15	1115	43.9	520	20.5	Incoloy	8.4	54	TLCLI315054	TLCP315054	15.4 (7)
18	1315	51.8	560	22.0	Incoloy	8.2	53	TLCLI318053	TLCP318053	15.4 (7)
3	565	22.2	400	15.7	Incoloy	4.6	30	TLCLI303030	TLCP303030	11.0 (5)
6	940	37.0	480	18.9	Incoloy	4.2	27	TLCLI306027	TLCP306027	13.2 (6)
9	1315	51.8	560	22.0	Incoloy	4.1	26	TLCLI309026	TLCP309026	15.4 (7)
3	940	37.0	480	18.9	Incoloy	2.1	14	TLCLI303014	TLCP303014	11.0 (5)
4.5	1115	43.9	520	20.5	Incoloy	2.5	16	TLCLI304516	TLCP304516	13.2 (6)
6	1315	51.8	560	22.0	Incoloy	2.7	18	TLCLI306018	TLCP306018	15.4 (7)

WHEN ORDERING, PLEASE SPECIFY: Quantity, catalogue number, voltage, phase, wattage, type of solution and container sheath.

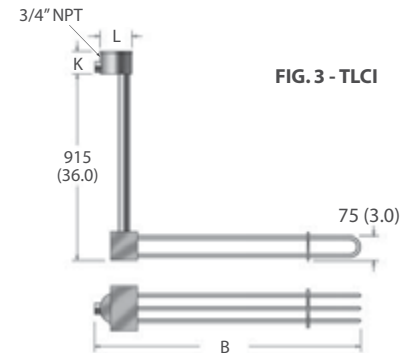

FIG. 3 - TLCLI

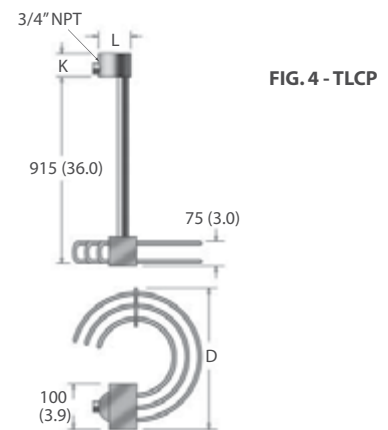

FIG. 4 - TLCP

OVER-THE-SIDE IMMERSION HEATERS

immersion heaters

OVERVIEW

WATTCO™ pipe-insert immersion heaters are perfect for solutions that are difficult to heat as they require low watt density and are mostly stored in large tanks. These heaters are primarily designed for heating viscous fluids. They are mounted in a pipe close to the bottom of a tank. The pipe evenly transfers the heat to stored liquids.

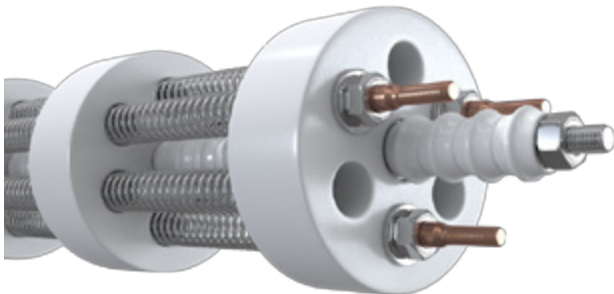

KEY FEATURES

- » Made of superior alloy-sheathed elements.
- » 3" 150 lb steel flange or 2" NPT screwplug.
- » Moisture-resistant terminal box.
- » Single 1" NPT conduit fitting for units without a thermocouple.
- » Extra ½" NPT conduit fitting for units with a built-in thermocouple.

Notes:

- » Thermocouples detect rises in temperature, then automatically shut the system off.
- » If the liquid level is beneath the uppermost part of the heater, the inside temperature of the heater's pipe will increase.
- » For detecting low liquid levels, use K-type thermocouple heaters with one thermocouple per tank.
- » Upon request, WATTCO™ can supply a control panel or ship the control components individually.

APPLICATIONS

- » Asphalt
- » Molasses
- » Tar
- » Paint
- » Glue
- » Viscous fluids
- » Corrosive liquids

Notes:

- » If devices are required in corrosive liquids, a corrosion-resistant pipe is required.
- » Pipes are normally supplied and installed by the tank manufacturer, unless specifically requested.
- » Removing the heater is done easily without draining the liquid.

FIG. 1 - Standard application of a pipe-insert immersion heater for viscous fluids

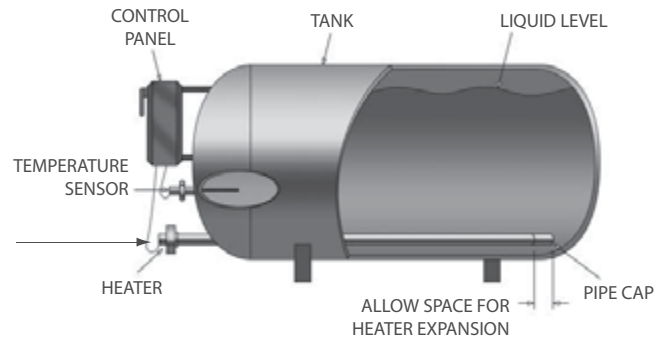

HEATING PROCESS

The heating element transfers the heat to the inner wall of the pipe by convection and radiation processes.

Note: Do not fill the pipe with a heat transfer fluid.

SELECTING

AND SIZING YOUR WATTCO™ PIPE-INSERT IMMERSION HEATER

- » Determine the kilowatts required to keep the tank at the required temperature.
- » Select the number of heaters required with an insert length that is long enough for good heat transfer.
- » Use single element or double element heaters in groups of three when installing a three-phase balanced system.
- » Select the single element heater for heating a viscous liquid from a cold start, as the lower watt density you will get on the pipe surface will prevent coking (refer to Table 1).

TABLE 1
Watt Density On Pipe Surface vs. Heater Type

PIPE SIZE	1 ELEMENT TYPE	2 ELEMENT TYPE	3 ELEMENT TYPE
2"	5.5	7.4	6.8
2 1/2"	4.6	6.2	5.7
3"	3.8	5.1	4.7
4"	3.0	4.0	3.7

EXTRA FEATURES

- » Bundle control systems
- » Custom voltages
- » Custom wattages
- » Explosion resistant terminal housings
- » Built-in thermostats/controls
- » Custom lengths
- » Custom flange or screwplug sizes
- » Additional conduit fittings